

This document contains the proprietary information of Tandemloc, Inc. and your access and use shall be, and is at all times, pursuant to and limited by the Tandemloc, Inc. Terms of Use. You shall not, and shall not encourage, assist, or authorize another party to copy, distribute, publicly display, modify, reverse engineer, decompile, or take any other action to reproduce this document or the information contained herein.

©2019 by Tandemloc, Inc.  
Dimensions are subject to manufacturing tolerance and change.

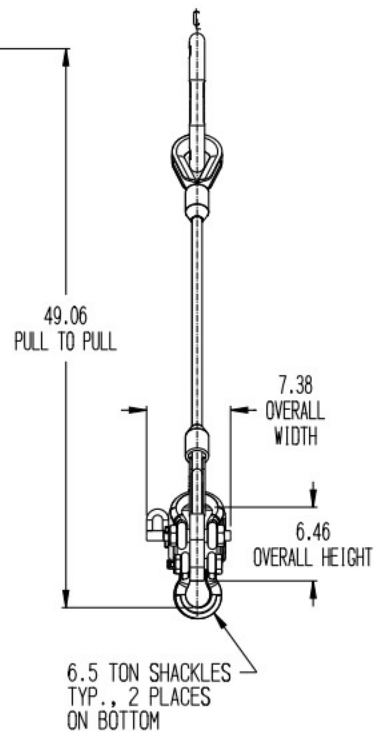
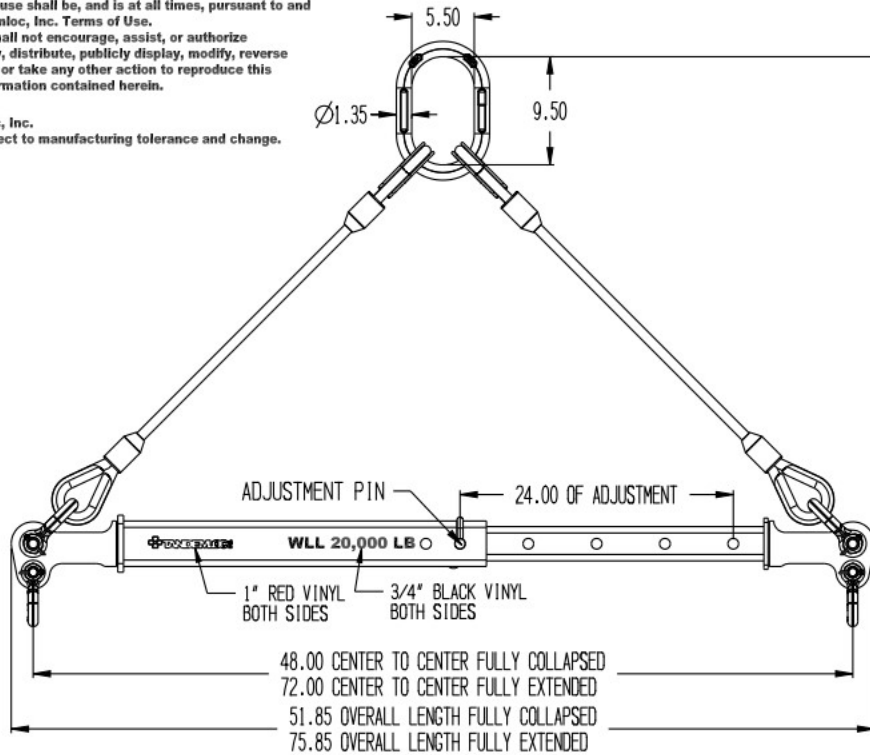

NOTES:

- PART NO.: AT14A020-072-PA, 48"-72" TELESCOPIC SPREADER  
 AT14A020-072SPA, 48"-72" TELESCOPIC SPREADER WITH TOP SLING
- WLL: 20,000 LB. @ 45° MINIMUM
- PROOF TESTED TO 125% (25,000 LB.) AND CERTIFIED
- STANDARD SPECIFICATION # EAD21000A APPLIES
- FINISH: SANDBLAST AND PRIME AND PAINT YELLOW
- CALCULATED WEIGHT: 130 LB. SPREADER WITH SLING: 178 LB.
- DESIGNED AND MANUFACTURED TO MEET OR EXCEED ASME B30.20 AND BTH-1, DESIGN CATEGORY B, SERVICE CLASS 0.

\*\* DO NOT SIGN IF CHANGES ARE REQUIRED \*\*

CUSTOMER APPROVAL: \_\_\_\_\_  
 DATE: \_\_\_\_\_

<small>1 1/2" DIMENSIONS APPLICABLE UNLESS OTHERWISE NOTED. DIMENSIONS ARE IN INCHES &amp; TOLERANCES ARE:          .XX ±.01          .XXX ±.01          THIS DOCUMENT CONTAINS ONLY INFORMATION AS OF THE DATE OF PRINTING. TANDEMLOC, INC. SUBSIDIARY OF TANDEMLOC HOLDING CO. ALL RIGHTS RESERVED. TANDEMLOC, INC. IS A REGISTERED SERVICE USER OF TANDEMLOC, INC. IS A REGISTERED SERVICE USER OF TANDEMLOC, INC. IS A REGISTERED SERVICE USER OF TANDEMLOC, INC.</small>	<small>1 1/2" DIMENSIONS APPLICABLE UNLESS OTHERWISE NOTED. DIMENSIONS ARE IN INCHES &amp; TOLERANCES ARE:          0 TO 4" ±.01          4.01" TO 7" ±.02          7.01" TO 30.0" ±.04          OVER 30.0" ±.06</small>		TITLE	AT14A020-072-PA 48"-72" TELESCOPIC SPREADER
			DATE	09-15-19
REV	0	65059	SAT14A020-072-PA	REV
SCALE				SHEET 1 OF 1